

SST

Splash-Proof Scale

The SST Splash-Proof weighing scale use high precision resistor stain type sensor and It is equipped with a large easy to read dual side LED display.

Mainly for the need of waterproof weighing.



Specifications:

UP to 1/6000~1/30000. internal resolution

Dual sides or single side pure RED LED display

With kg, gm, lb, & Oz units conversion

Pan size: 180x215mm

Tare within full capacity, and pre-tare function

Large LED character height=26.5mm

Environment temperature 0° C ~ 50° C

Storage and transportation temperature -25° C ~ 55° C

warm up time 10~15 minuts

Rechargeable battery, 220V AC power supply

Capacity	Readability	Pan Size
15 kg	0.001 kg	180x215mm

Splash-Proof Weighing Scale

SST

Splash-Proof Scale

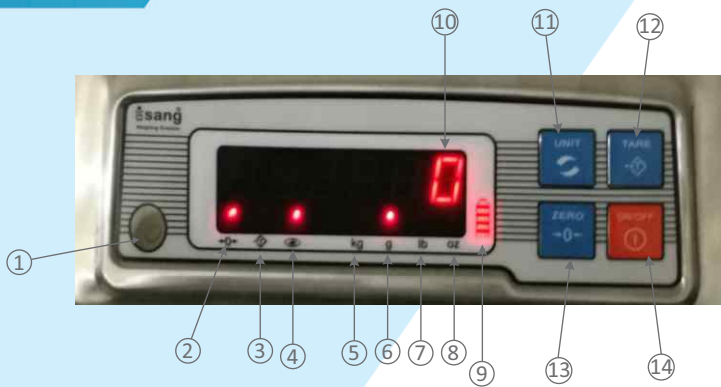

- 1- water level
- 2- Zero
- 3- Tare
- 4- Stability
- 5- Kg unit
- 6- gm unit
- 7- lb unit
- 8- oz unit
- 9- battery charging
- 10- weight window
- 11- Unit key
- 12- Tare Key
- 13- Zero Key
- 14- On Off Key

Physical Dimension

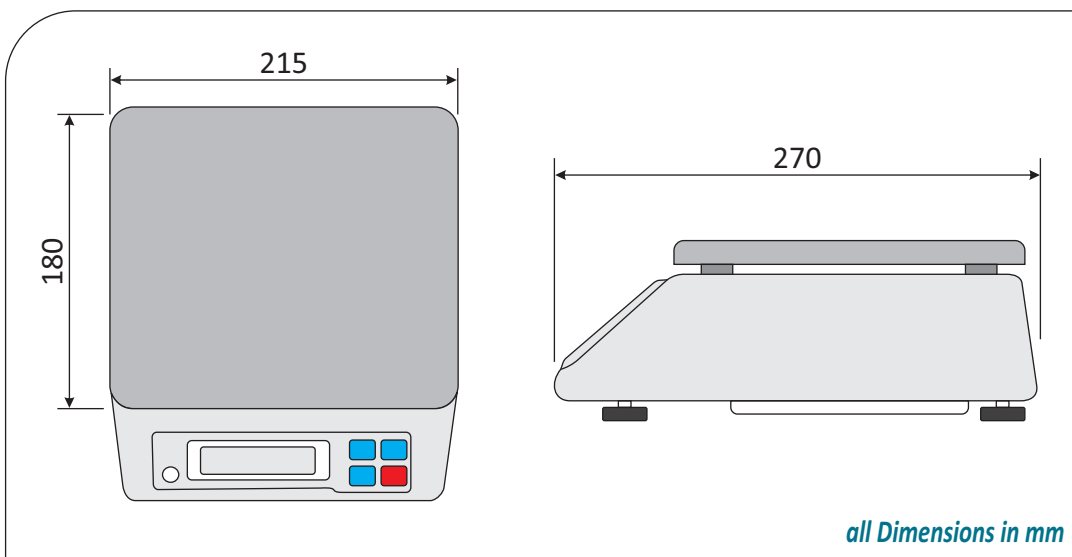

Reliable and Rugged! **CE**